

Assembly instructions

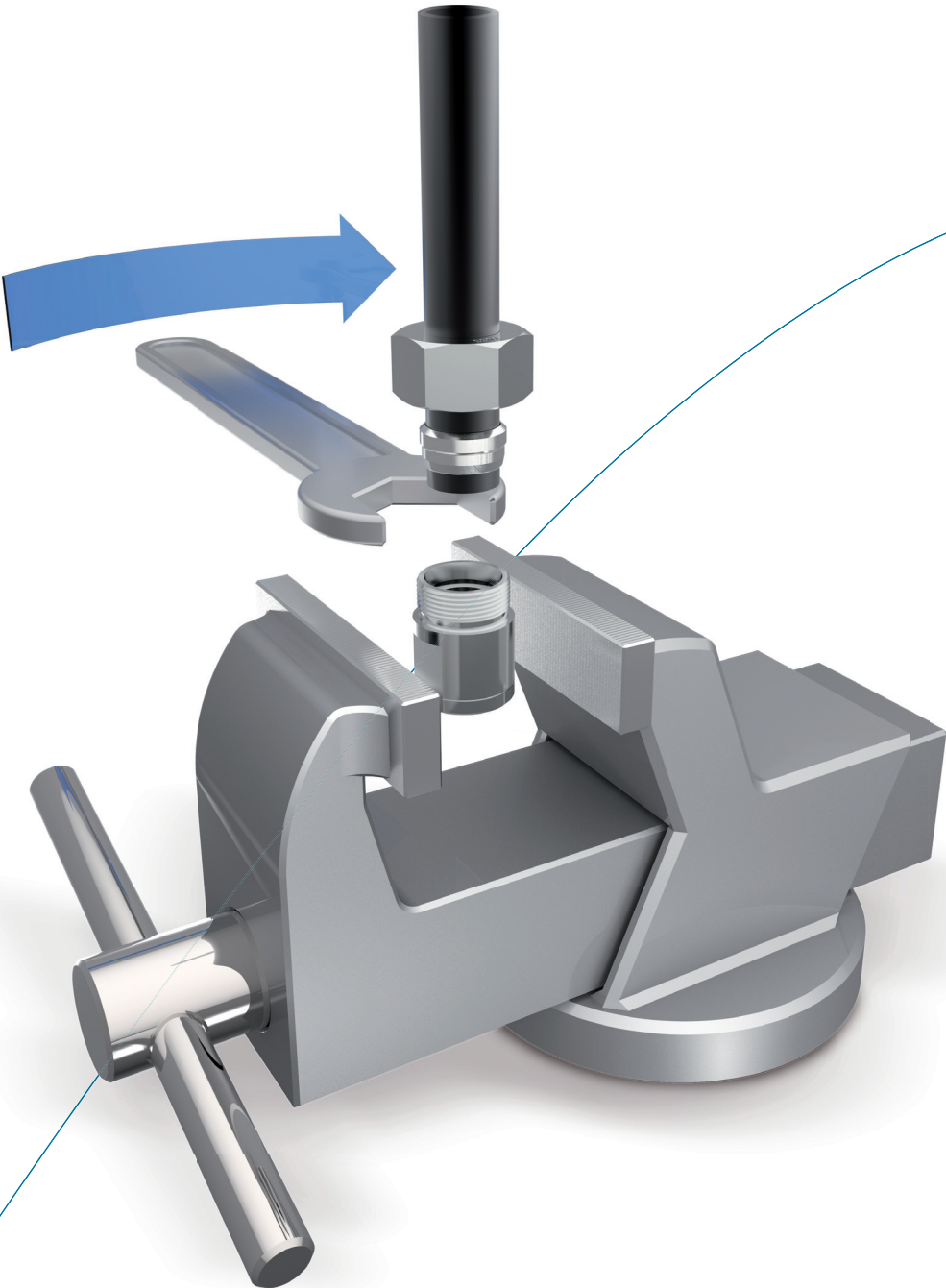

## Important notes on VOSS assembly instructions

In order to ensure maximum performance and functional reliability of VOSS products, the respective assembly instructions, operating conditions and tube recommendations have to be adhered to.

We recommend that you use VOSS pre-assembly devices at all times. It is absolutely essential to follow the operating instructions for the respective pre-assembly device used.

Do not start with assembly until you are absolutely sure that you have understood the operating and assembly instructions for each VOSS pre-assembly device or machine, tool and product. Incorrect handling leads to risks regarding safety and leak-tightness and can result in failure of the entire connection.

It is impossible for the manufacturer to monitor whether the user is adhering to the operating and assembly instructions for individual pre-assembly devices or machines, tools and products, as well as what conditions prevail and what methods are used for installation, operation, application and maintenance of the individual products. Improper workmanship can lead to material damage, which in turn may pose a danger to life and limb. This means that VOSS Fluid GmbH can accept no responsibility or liability for loss, damage or costs incurred due to faulty installation, improper operation or incorrect application and maintenance or from any related issue. Failure to heed this warning will lead to loss of guarantee.

VOSS Fluid GmbH reserves the right to make changes or additions to the information provided without prior notification. Customers can obtain the latest version of the operating and assembly instructions upon request, or from our download area at: [www.voss.net](http://www.voss.net)

## General notes on VOSS assembly instructions

Make sure that all components, including the tubes, are clean before assembly is started and that they remain clean during the entire assembly process. Soiled components may lead to failure of the system.

Before starting assembly, make sure that you have carried out all preparatory work in accordance with the respective instructions.

### Specifications concerning permissible steel tubes:

seamless, cold-drawn and normalized precision steel tubes as specified in DIN EN 10305-4, material E235+N, mat. no. 1.0308+N or E355, mat. no. 1.0580. The tubes must be ordered by specifying the outer diameter and the inner diameter.

### Specifications concerning permissible stainless steel tubes:

seamless, cold-drawn and solution-annealed, scale-free stainless steel tubes in CFA or CFD delivery condition of dimensions and tolerances according to DIN EN 10305-1 and all other delivery conditions as specified in DIN EN 10216-5, material X6CrNiMoTi17-12-2, mat. no. 1.4571. The tubes must be ordered by specifying the outer diameter and the inner diameter.

The tubes should be prepared with the same thoroughness as pre-assembly and final assembly of the connection. Especially when using long tubes, check the end sections for damage or distortion.

We recommend that pre-assembled tubes which are not to be finally assembled yet should be fitted with protective caps.

Marking a stroke on the union nut and the tube makes it easier to achieve the correct number of turns when tightening the coupling.

Before starting to assemble VOSS components with elastomer seals, always check that:

- the nut and the seal surfaces are clean and undamaged and/or
- the elastomer sealing is clean and undamaged

## Determining the tightening torque for screw couplings

The tightening torques specified in the catalogue apply under the following conditions:

- steel fittings with VOSS coat surface coating
- the specified nominal pressure ranges assume that the mating material has a tensile strength of  $\geq 600 \text{ N/mm}^2$
- our recommendations on lubrication of the threaded studs are observed

If other values for strength, modulus of elasticity and friction-surface combinations are used, the user has to adapt the tightening torque empirically.

The recommended tightening torques have to be adhered to if the pressure range is to be fully utilized and the appropriate safety level is to be maintained.

The recommended tightening torques for the threads are given in the tables for the respective type of thread.

## Explanation of symbols and other notes



Visual inspection



Turn until hand-tight or carry out another manual activity



Use the tool to tighten the coupling according to the instructions



Oil and lubricate at the point marked with an arrow

All dimensions in millimetres [mm]

# Assembly instructions for VOSSForm<sup>SQR</sup>VA tube couplings

## 1

### Notes

Before starting the assembly work, read and observe the general notes in the up-to-date VOSS catalogue and check that your assembly instructions are up to date.

These assembly instructions describe the tube forming and the final assembly of VOSSForm<sup>SQR</sup>VA.

These assembly instructions are not a substitute for the detailed operating instructions of the forming device used. They only describe the basic tube preparation, forming and final assembly steps.

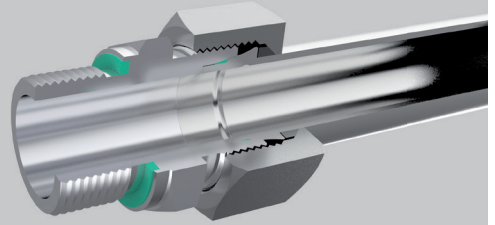

## 2

### Tube preparation

**2.1** When determining the tube lengths to be used, dimensions L1 and L2 have to be taken into consideration. The forming process compresses the tube and shortens it by the length L1.

In addition, the minimum lengths A1, A2 and B1, B2 required for clamping the tube ends have to be taken into consideration.

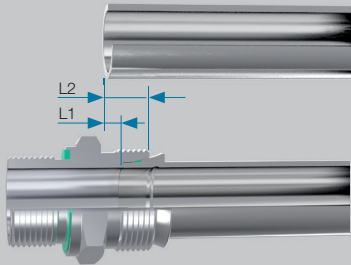

Height of the completely assembled VOSSForm<sup>SQR</sup>VA connection.

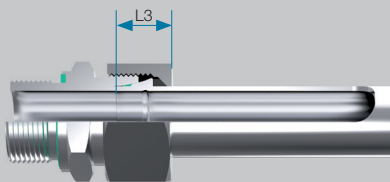

Series	Tube OD [mm]	s [mm]	L1 [mm]	L2 [mm]	L3 approx. [mm]	A1 [mm]		A2 [mm]		B1 [mm]	B2 [mm]
						R <sub>e</sub> 3xDN α≤45°	R <sub>e</sub> 3xDN α≤90°	R <sub>e</sub> 3xDN α≤45°	R <sub>e</sub> 3xDN α≤90°		
L	6	1	5.6	12.6	15.5	60	69	47	56	82	56
		1.5	6.1	13.1	16.0						
		2	5.5	12.5	16.0						
L	8	1	5.5	12.5	15.5	60	64	47	51	82	56
		1.5	5.7	12.7	16.0						
		2	5.2	12.2	16.0						
		2.5	4.7	11.7	16.0						
L	10	1	5.8	12.8	15.5	60	60	47	47	83	57
		1.5	6.0	13.0	16.0						
		2	5.2	12.2	16.0						
L	12	1	5.9	12.9	15.5	60	60	47	47	83	57
		1.5	5.7	12.7	16.0						
		2	5.1	12.1	16.0						
L	15	1.5	6.5	13.5	17.5	70	70	56	56	96	68
		2	5.8	12.8	17.5						
		2.5	5.6	12.6	17.5						
L	18	1.5	6.7	14.2	18.5	75	75	61	61	101	73
		2	5.8	13.3	18.5						
		2.5	5.5	13.0	18.5						
		3	5.8	13.3	18.5						
L	22	1.5	7.1	14.6	20.0	85	85	70	70	113	83
		2	6.6	14.1	20.0						
L	28	2	6.7	14.2	19.5	93	93	79	79	120	92
		2.5	6.2	13.7	19.5						
		3	6.3	13.8	19.5						
L	35	2	9.0	19.5	24.0	107	107	87	87	142	102
		2.5	8.1	18.6	24.0						
		3	8.6	19.1	25.0						
L	42	2	8.4	19.4	24.5	117	117	97	97	152	112
		3	8.6	19.6	25.5						

Minimum lengths for clamping in straight tubes.

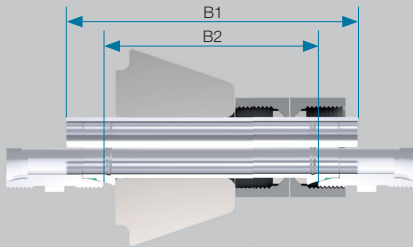

Minimum lengths for clamping in curved tubes (R ≥ 3x Tube OD).

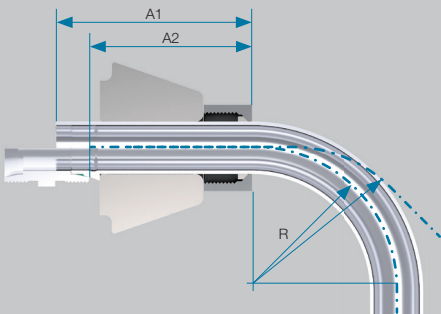

Series	Tube OD [mm]	s [mm]	L1 [mm]	L2 [mm]	L3 approx. [mm]	A1 [mm]		A2 [mm]		B1 [mm]	B2 [mm]
						R≥3xDN α≤45°	R≥3xDN α≤90°	R≥3xDN α≤45°	R≥3xDN α≤90°		
S	6	1	5.6	12.6	16.0	62	69	49	56	85	59
		1.5	6.1	13.1	16.5						
		2	5.5	12.5	16.5						
S	8	1	5.5	12.5	16.0	62	64	49	51	85	59
		1.5	5.7	12.7	16.5						
		2	5.2	12.2	16.5						
S	10	1.5	6.7	14.2	18.5	64	64	50	50	90	62
		2	5.9	13.4	18.5						
		2.5	5.5	13.0	18.5						
S	12	1.5	6.3	13.8	18.5	64	64	50	50	90	62
		2	5.7	13.2	18.5						
		2.5	5.3	12.8	18.5						
S	14	1.5	6.7	14.7	20.5	72	72	57	57	101	71
		2	6.3	14.3	20.5						
		2.5	5.7	13.7	20.5						
S	16	1.5	7.2	15.7	21.0	77	77	61	61	107	75
		2	6.2	14.7	21.0						
		2.5	6.0	14.5	21.0						
S	20	2	8.5	19.0	25.0	88	88	69	69	122	84
		2.5	7.7	18.2	25.0						
		3	7.3	17.8	25.0						
S	25	2	8.7	20.7	28.0	103	103	82	82	140	98
		2.5	8.0	20.0	28.0						
		3	7.6	19.6	28.0						
S	30	4	7.6	19.6	28.0						
		2.5	8.1	21.6	30.5	114	114	92	92	155	111
		3	8.7	22.2	31.5						
S	38	4	8.4	21.9	31.5						
		3	10.3	26.3	34.5	134	134	108	108	180	128
		4	10.2	26.2	35.5						
		5	9.8	25.8	35.5						

**2.2** Cut off stainless-steel tubing at right angles. An angle tolerance of ±1° is permissible. Do not use tube cutters or angle grinders to cut tubes.

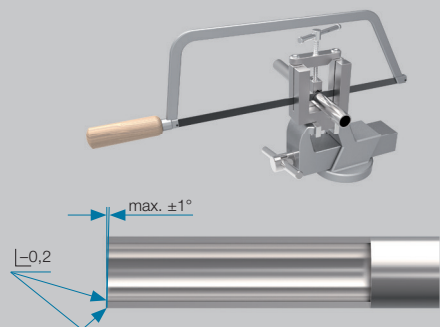

## VOSSForm<sup>SQR</sup> VA

**2.3** Slightly deburr tube ends inside and outside.  
Clean the tube.

**Attention!**

Burrs on the outer and inner edges of the tube end can impair the forming process. Tubes which are not cut off squarely and correctly deburred may reduce the service life and leak-tightness of the couplings.



### 3

Lubricating tools and stainless steel tubes

**3.1** Lubricating the tools

**Clamping jaws:**

After every tool change and after roughly 100 forming procedures, the outer part of clamping jaw taper must be lightly lubricated using hydraulic fluid or a non-resinous lubricant containing MoS<sub>2</sub>. VOSS recommends that separate sets of clamping jaws be used if steel and stainless steel tubes are being used both at the same time.

**Attention!**

Ensure that no oil is applied to the teeth of the clamping jaw, otherwise the gripping function may be impaired.

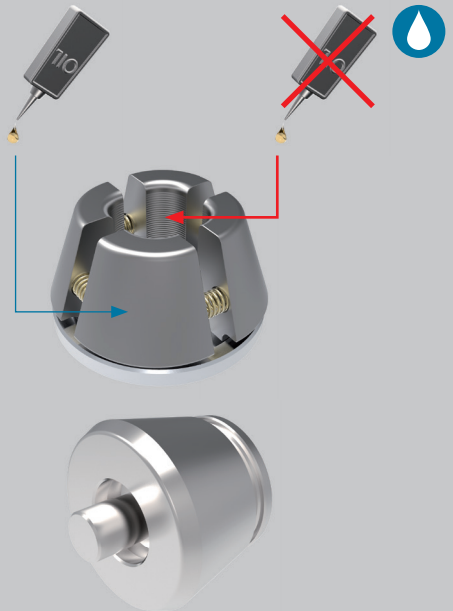

**3.2** Lubricating the stainless steel tubes

To ensure fault-free forming, each tube must be lubricated on the inside and outside in the forming area with a thin film of oil. (VOSS forming oil FOE).

**Attention!**

If the lubricant film on the outer tubing surface is too thick, it will be trapped between the forming tool and the tube, thus leading to inaccurate contours. Always use VOSS forming oil FOE. (The use of normal hydraulic oil is not allowed).

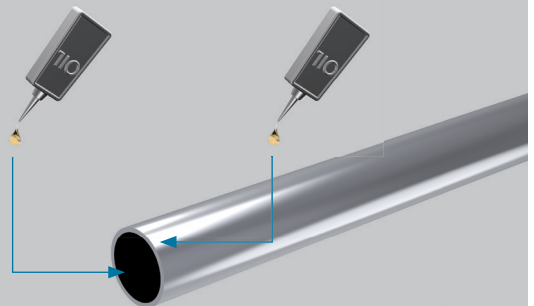

## VOSSForm<sup>SQR</sup> VA

4

### Notes on tube forming

**4.1** Prepare the tube forming device as described in the operating instructions and insert the tools.

**4.2** Push the SQR-function nut onto the prepared tube end.

**4.3** Form the tube as described in the operating instructions.



5

### Checking the results

It is adequate to visually inspect the quality of the three characteristic VOSSForm<sup>SQR</sup> features.

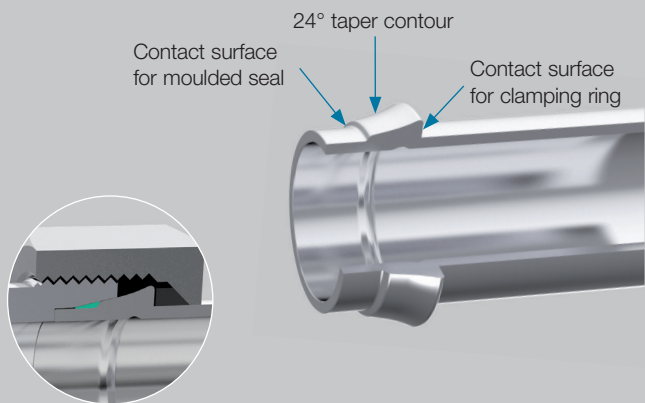

6

Final assembly



**6.1** Install the moulded seal, ensuring that it is not twisted or damaged.

Push the pre-assembled tube end straight into the taper of the coupling connecting piece.

**6.2** Apply a light film of assembly paste (e.g. MPE assembly paste) to the threads, the formed tube end, the SQR special function nut and the moulded seal.

**6.3** Turn the SQR special function nut until it is hand-tight.

To achieve the final tightening torque, turn the SQR special function nut by approx. **1/2 to 3/4 of a turn**.

If the coupling is being installed on an already-installed piping system, hold the coupling connecting piece with a spanner when tightening the coupling.

Marking a stroke on the SQR-function nut and the tube makes it easier to achieve the correct number of turns when tightening the coupling.

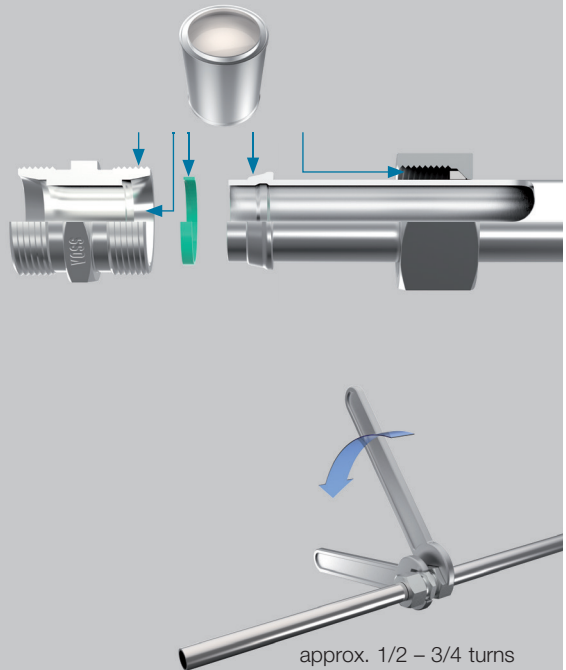

7

Re-assembly of couplings



**7.1** Every time the coupling is taken apart, the moulded seal must be checked for damage and, if necessary, replaced.

**7.2** For second and all following re-assembly processes, the SQR-function nut must be tightened by only **1/4 to 1/2 turns** after it has been hand-tightened.

**Attention!**

Before re-assembling the coupling, the 24° taper contour, the moulded seal contact surfaces and the clamping ring must be checked for damage (see 5: Checking results).

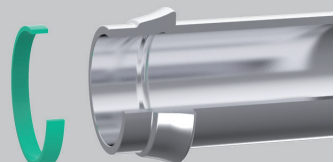



8

Tightening torques

**8.1** As an alternative to achieving pre-assembly and final assembly states by distance dependent assembly, the tightening torques are guideline values which have been determined using MPE assembly paste.

Tube specifications as given in the general notes.

Series	Tube OD [mm]	Tightening torque Nm ± 5 %
L	6	25
L	8	35
L	10	55
L	12	65
L	15	90
L	18	125
L	22	150
L	28	220
L	35	380
L	42	580
S	6	30
S	8	50
S	10	65
S	12	85
S	14	115
S	16	125
S	20	220
S	25	300
S	30	430
S	38	640